

Swedish Electroforming Technology AB



POLARIS

Stamper Treatment System

- > Automatic anodic passivation for full family making
- > Automatic Cathodic/Anodic cleaning
- > Automatic cleaning of used stampers
- > Pat. pending self locking spin chuck for low and high speed spinning
- > Workbench for work holder preparation
- > Work holder storage
- > User-friendly programmable software
- > Stand alone system

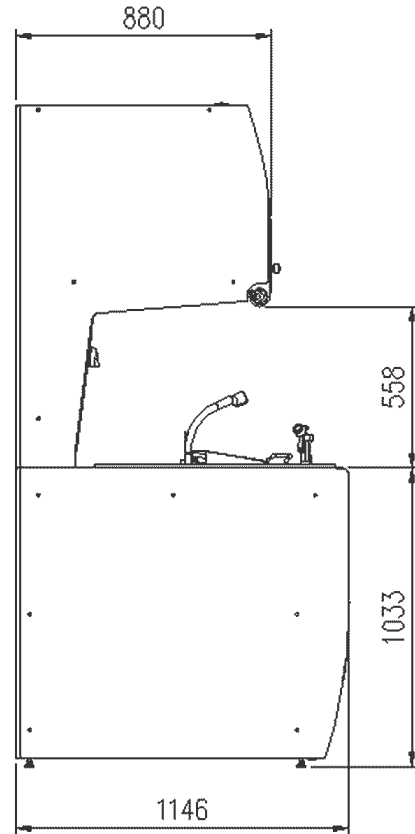
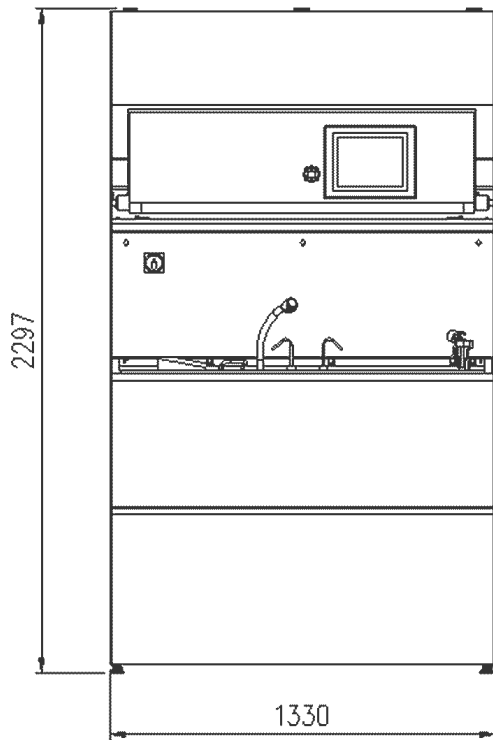

- Formats:** All optical disc diameters up to 240 mm.
- System control:** Industrial PLC
- Operator interface:** Color touch screens
- Tank level alarms:** Low, very low

- Filter system:** 1 x 5", 5 μ
- Temp. control:** Controlled from PLC.
0.5 kW stainless steel immersion heater.
- Optional:** Heated chemical storage tank

POLARIS STAMPER TREATMENT SYSTEM

The most user-friendly treatment system on the market.

POLARIS has features that really help the operator maintain a high productivity and quality level. Many time-consuming functions have now been made automatic.

On-screen process monitoring gives the operator information about the process parameters. Users programmable recipes insure good process repeatability. The station has built-in HEPA class 100 filters that eliminates dust particle contamination.

The cabinet is fully contained with all components within the footprint area. This also gives flexibility of location. Just consistent high quality production with a minimum of down time.

Our technicians have a long history and thorough experience of developing, manufacturing and servicing Electroforming systems.